

DETTAGLIO A  
SCALA 2 : 15

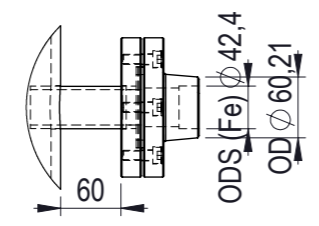

DETTAGLIO B  
SCALA 2 : 15

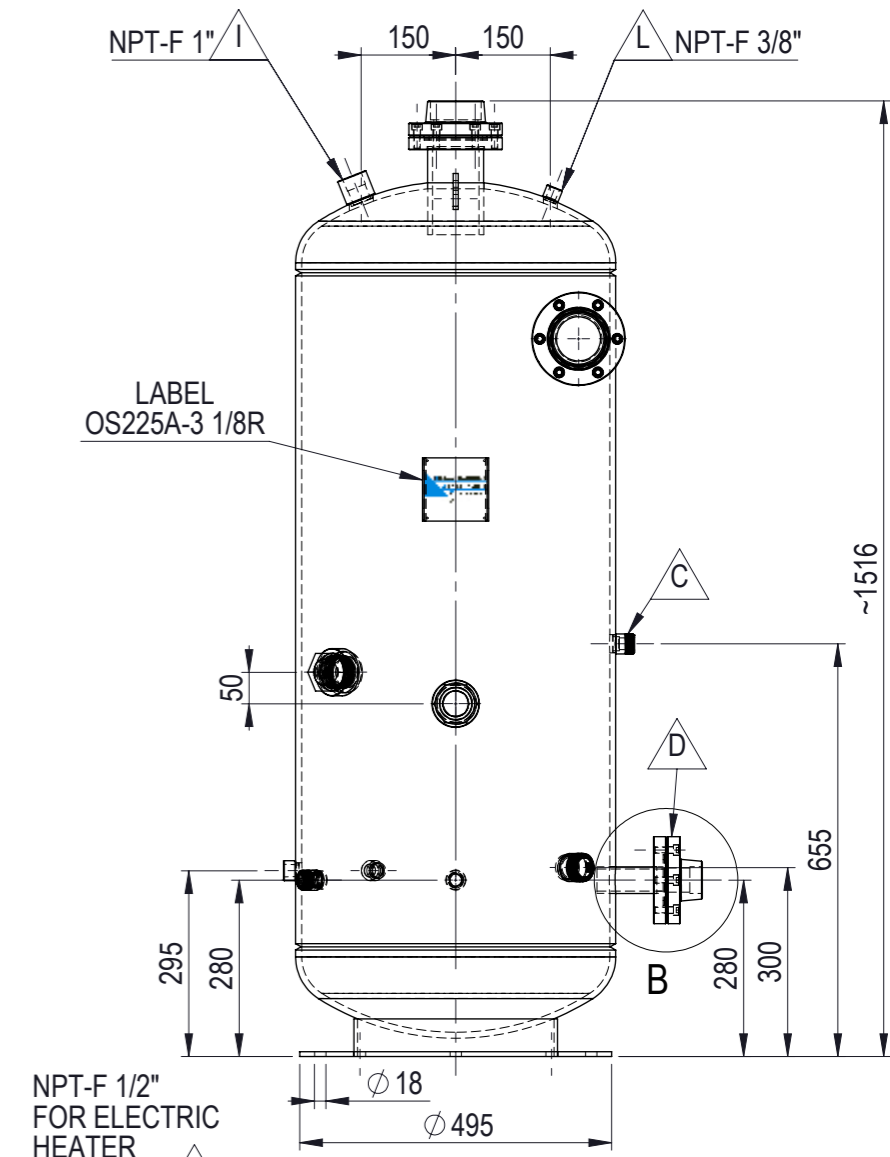
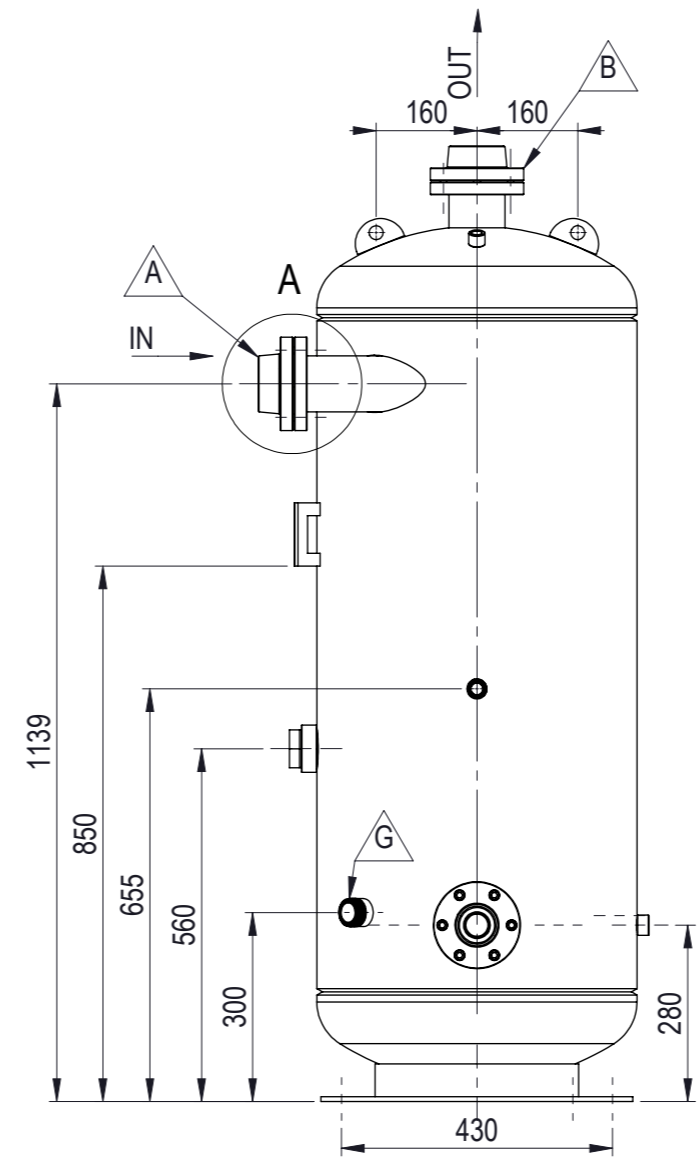

NPT-F 1/2"  
FOR ELECTRIC  
HEATER  
(OPTION)

NPT-F 1/2"  
FOR THERMOSTAT  
(OPTION)

ROTALOCK 1 1/4

ROTALOCK 1 1/4

SIGHT GLASSES  
M52X2 (x2)

Tolleranze di lavorazione: ISO 2768-C

**INDIVIDUAL  
PACKING  
RAL 3005**

Pos	Connections
A	IN
B	OUT
C	PRE-CHARGE OIL IN
D	OIL OUT (MAIN)
E	OIL OUT (SEC.)
F	OIL HEATER
G	LIQUID LEVEL
H	THERMOSTAT
I	SAFETY VALVE
L	ACCESSORY

Item Number	Description	Quantity
1	HEAD Ø508	2
2	TUBE Ø323,9	1
3	TUBE Ø508	1
4	TUBE Ø42,16	1
5	TUBE Ø88,9	1
6	TUBE Ø88,9	1
7	EYELIFT	2
8	BASE SUPPORT Ø495 H.Ø18	1
9	PLATE SUPPORT 105X100	1
10	ROTALOCK 1 3/4 - 12UN	1
11	SIGHT GLASS SLEEVE M52X2	2
12	1" NPT-F	1
13	1/2" NPT-F	4
14	3/8" NPT-F	1
15	ROTALOCK 1 1/4 - 12 UNF	2
16	MALE FLANGE ODSØ42,4	1
17	MALE FLANGE ODSØ80,4	2
18	FEMALE FLANGE FIL.M10	2
19	FEMALE FLANGE FIL.M10	1
20	SCREW M10X30	18
21	SIGHT GLASS M52X2 DS40 (TÜV)	2
22	GASKET FLANGE	1
23	GASKET FLANGE	2
24	SIGHT GLASS GASKET M52X2	2
25	METAL LABEL	1

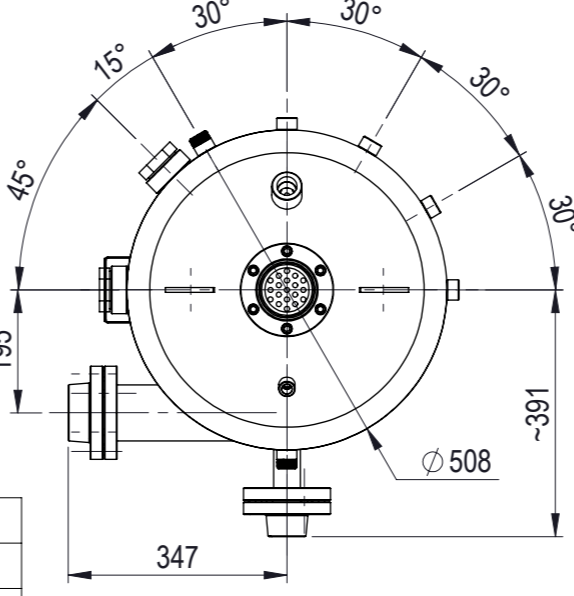

Rev.	Data-Date	Dis.-Draftsman	Visto-Checked by	Descrizione Revisione - Revision Description
Denominazione - Denomination				Codice Disegno - Drawing Code
<b>OIL.SEP.225LT.Ø508X1300 PS32BAR - OS225-3 1/8R</b>				<b>SOIR225A</b>
PS - Design 32 BAR	PW - Work 32 BAR	PT - Test 48 BAR	Temperatura - Temperature -10°C +120°C	Refrigerant HFC, HCFC
Scala-Scale 1:15		Data-Date 14/04/2014	Disegnatore - Draftsman G.BOKARIS	Visto-Checked by S.SPINELLO
Materiale - Material		Spessore - Thickness	Colore Vernice-Painted Colour RAL 3005 - RED	Prodotto e Realizzato Secondo Direttiva 97/23/CE Produced and Made According to Directive 97/23/CE
Categoria PED CAT. IV				Peso - Weight [kg] 237.82
Codice Disegno - Drawing Code <b>SOIR225A</b>				Rev. 0
OCSCOLD Innovation & Technologies Property of OCSCOLD SRL				Cod.STD. OS225A